

ONE Top Milk XP with KS9 Countertop Fridge

High Volume Super Automatic Espresso Machine

The Egro ONE is a high volume fully automatic espresso machine with a touchscreen user interface. It features a stainless steel 18-gram patented brew group with advanced sealing technology. This makes the brew group the most durable in its class, reduces maintenance needs, and lowers the cost of ownership. The ONE uses dual Ditting® grinders with stainless steel burrs for quick and consistent grinding. The body of the machine features stainless steel and ABS plastic construction. Milk is pumped from the countertop fridge. Includes the ability to set different milk temperatures and textures for each drink.



Standard Features

- Standard 5.7" full-color touchscreen graphical user interface enables up to 48 drink selections
- Single milk pump system
- Americano bypass enables machine to deliver authentic Americanos into a single cup
- The KS9 countertop fridge (6.5L/1.7 gal) fits perfectly on the left side of the machine.
- Lowest cost of ownership of any fully automatic
- Premium espresso brewing
- Centralized hot water
- USB port makes it simple to save drink parameters and facilitates software and programming updates
- Stainless steel 18-gram patented brew group
- Dual Ditting® grinders with stainless steel burrs
- Made of stainless steel and ABS plastic
- Single component two-piece dispensing outlet for easy cleaning
- Daily milk cleaning cycle only requires the operator to add detergent
- 2 year parts warranty

Accessories in the Box

- Plastic grounds bin container
- One-month supply of daily cleaning products
- Milk container
- Container for daily milk cleaning
- User manual
- Foot extensions

Options

iSteam: Intelligent steam wand automatically froths and steams milk; shuts off at programmed temperature

Self-Adjusting Grinder: Automatically adjusts the coffee grind size to compensate for environmental changes

Under Counter Grounds Chute: Chute that diverts ground coffee to an under counter waste container (not available when fridge is installed directly under the machine)

External Hot Water Outlet: Hot water delivered through a separate outlet to the right of the drink spout

Self-Service Package: Includes locks for hopper, grounds drawer, and fridge, as well as cup stopper pins for the drink tray

Powder Module: Enables machine to deliver up to 2 types of powder, such as chocolate for mochas and for hot chocolate

Space Requirements

Allow at least one and a half inches (1.5") of clearance from the back of the machine to the nearest wall for air circulation.

Allow at least four inches (4") of clearance above hoppers to refill. (recommended 12")

Allow 24" x 5" for in-line filter. Filter can be mounted behind the machine or under the counter.

Fridge Features

The KS9 Fridge fits next to the machine or undercounter, and automatically pumps milk into the machine. Also includes a 1.7 gal. container that maximizes milk storage and a sensor that allows the machine to determine milk levels automatically. Alternatively, a standard 1 gal. milk container may also be used.

ONE Top Milk XP with KS9 Countertop Fridge

High Volume Super Automatic Espresso Machine

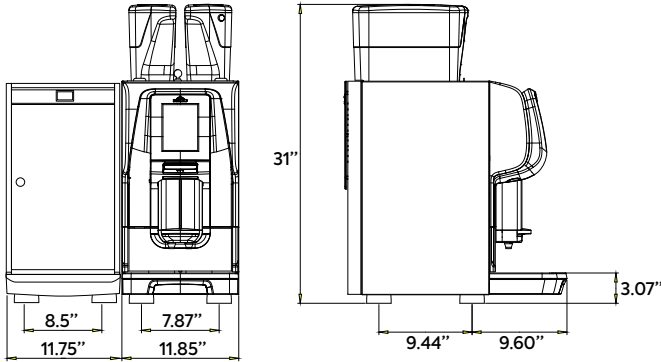

Countertop Requirements

Espresso Machine w/ Countertop Fridge

Width	Depth	Height	Weight
24"	23"	31"	190 lbs

Shipping Dimensions and Weight

Espresso Machine w/ Countertop Fridge

Length	Width	Height	Weight
36"	36"	33"	235 lbs

Countertop Drilling Plan

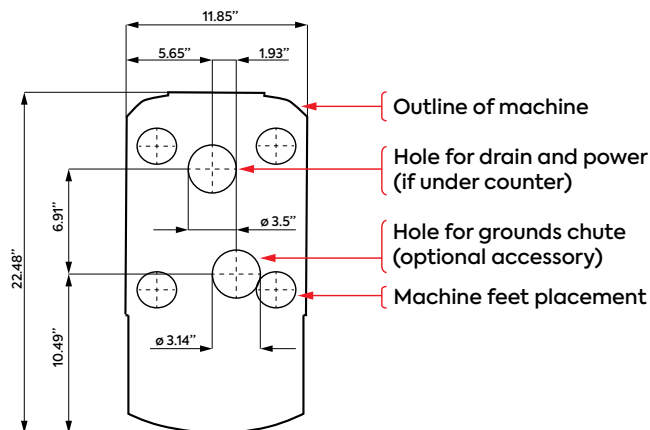

Electrical Connections

Espresso Machine

Voltage Range: 208-240VAC

Power: 6000W

Circuit Size: 30A

Suggest Receptacle: NEMA L6-30R

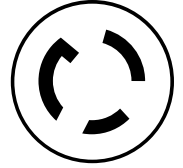

KS9 Countertop Fridge

Voltage Range: 110-120VAC

Power: 200W

Circuit Size: 15A

Suggest Receptacle: 5-15R GFI

NOTE: Egro machines do not use a neutral line. A dedicated ground wire is required.

Power can be installed under or above the counter. Please allow 3.5"-4" of space for the plug, especially when placing power above the counter and behind the machine.

Water Connections

Dedicated cold water access line with standard female 3/8" NPT fitting and manual shut-off valve within 4' of the machine required.

Drain Requirements

Open gravity drain with minimum 2" I.D. within 4' of the machine.

Water Quality Statement

The fact that water is potable is no guarantee that it is suitable for coffee machines. Your water supply must be within these general guidelines:

SUPPLY PRESSURE: 30-70 psi

HARDNESS: 2-3 GPG (1 grain of hardness = 17.1 ppm)

Water entering the machine should have a water hardness level of 2-3 GPG at all times. If the water supply is not within this range, a dedicated water softener (if above 3 GPG) or mineral addition cartridge (if below 2 GPG) is required for the coffee machine to operate properly over time (see Rancilio Group North America Water Quality Statement for further details).

Ditting is a registered trademark of Ditting Maschinen AG.

